

| REVISIONS | | | | |
|-----------|--------------------|----------|-------|------|
| REV | DESCRIPTION | DATE | DRAWN | CK'D |
| A | AS PER ECN 1087701 | 11/12/14 | L&T | MWS |

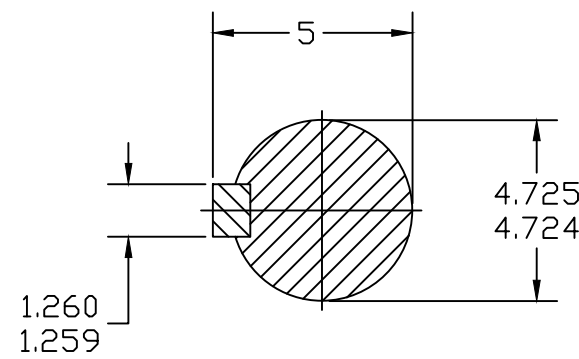
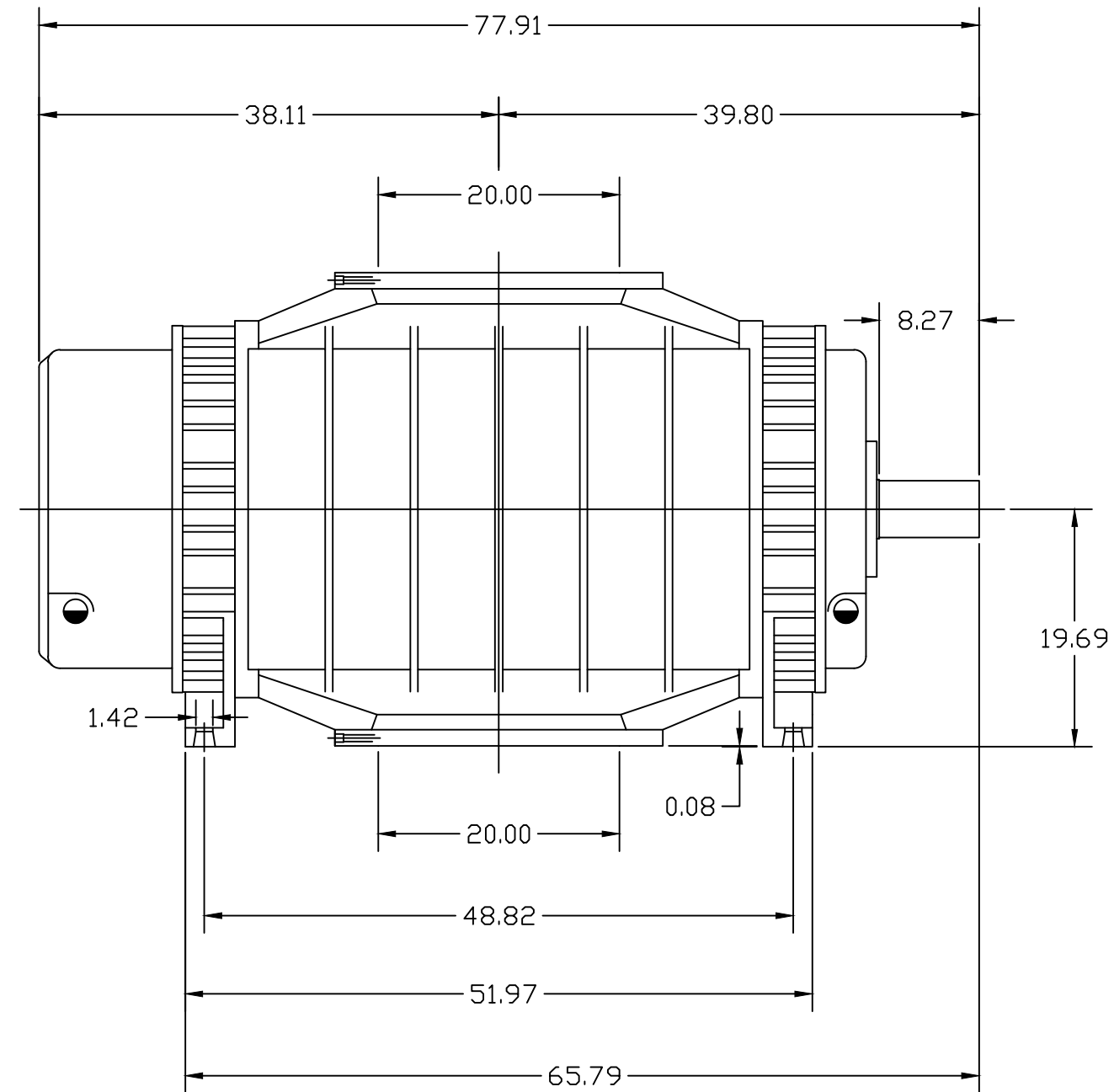
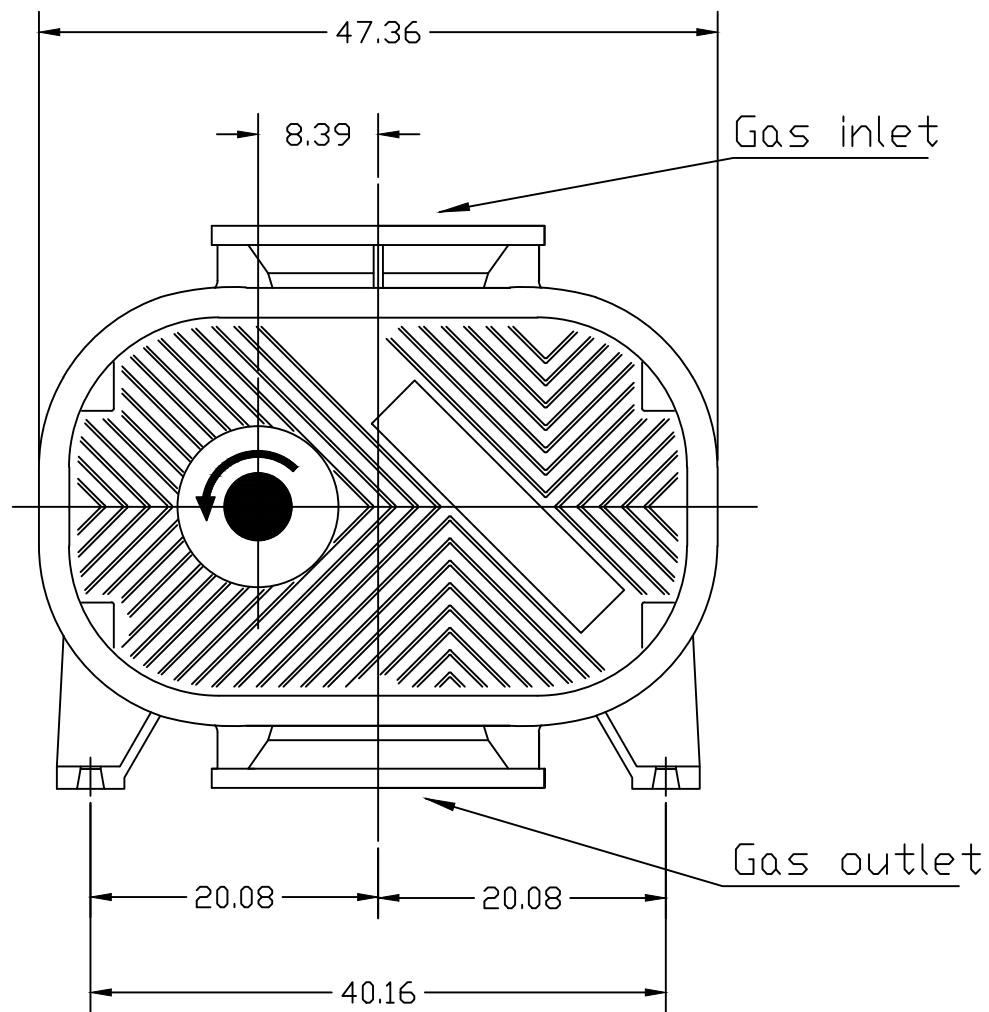

TOTAL WEIGHT 7209 lbs

FINISH OF CHAMFERS & FILLETS TO CONFORM TO ROUGHEST ADJACENT AREA.
SURFACE ROUGHNESS MAX. PER ASME B46.1 SPEC.
FULL THD DEPTHS ARE MINIMUM.

CONFIDENTIAL - THE INFORMATION CONTAINED IN THIS DOCUMENT IS THE PROPERTY OF GARDNER DENVER, INC. IT IS NOT FOR PUBLIC DISCLOSURE. POSSESSION OF THE INFORMATION DOES NOT CONVEY ANY RIGHT TO LOAN, SELL OR DISCLOSE THE INFORMATION. UNAUTHORIZED REPRODUCTION OR USE OF THE INFORMATION IS PROHIBITED. THIS DOCUMENT IS TO BE RETURNED TO GARDNER DENVER, INC. UPON THE COMPLETION OF THE PURPOSE FOR WHICH IT IS LOANED OR UPON REQUEST.

UNLESS OTHERWISE SPECIFIED
DIMENSIONS ARE IN INCHES
TOL. ON DECIMALS: .X = ±.05
TOL. ON DECIMALS: .XX = ±.02
TOL. ON DECIMALS: .XXX AS SPECIFIED
TOL. ON ANGLES: ± 0°-30'

DIMENSIONING AND TOLERANCING PER ASME Y14.5-2009
THREADS PER ASME B1.1 GAGING SYSTEM 21 U.O.S., ANSI B1.20.1 & B1.20.3

Gardner Denver HEAT TREATMENT ENG. REF: 276520-0000

Gardner Denver Inc. Quincy, IL. TITLE OUTLINE-BARE UNIT RBS 225-HORIZONTAL

THIRD ANGLE PROJECTION

DWN BY L&T 11/12/14 SIZE C ENGR. APPROVAL DWG NO. 347RBS800 REV A

CK'D BY MWS 11/12/14

SCALE 1:1 SHEET 1 of 1