

4

3

2

1

REVISIONS				
REV	DESCRIPTION	DATE	DRAWN	CK'D
A	AS PER ECN NO 1085111	07/11/14	L&T	MWS

D

D

C

C

B

B

A

A

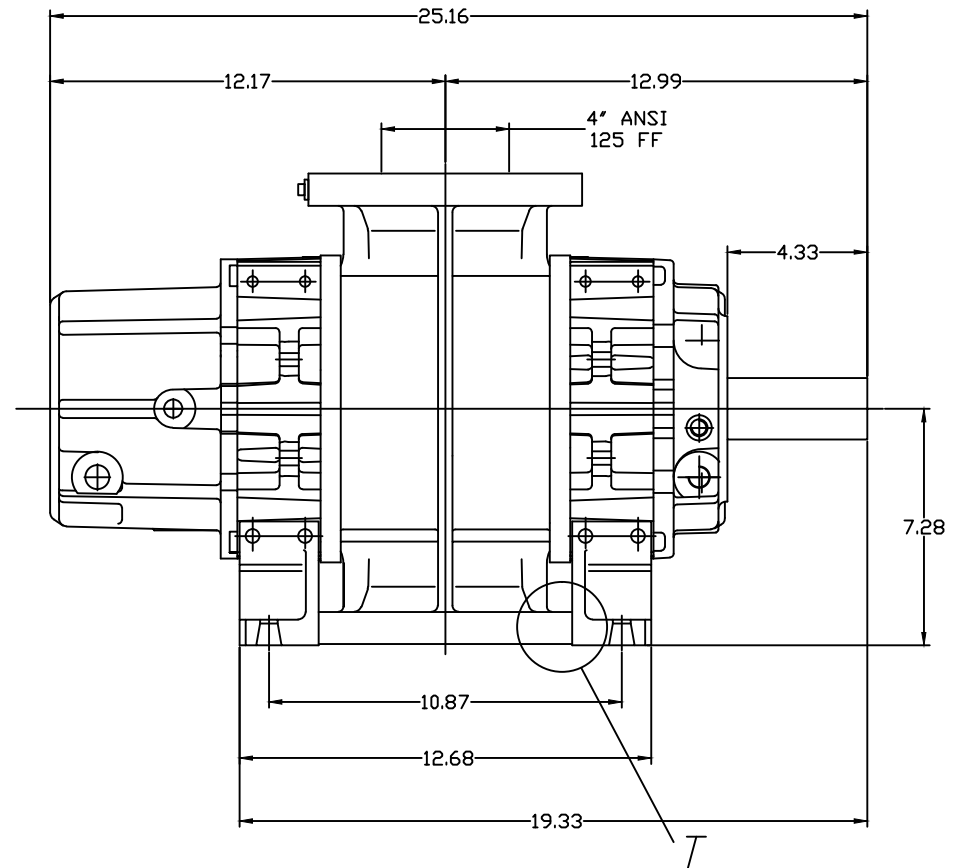
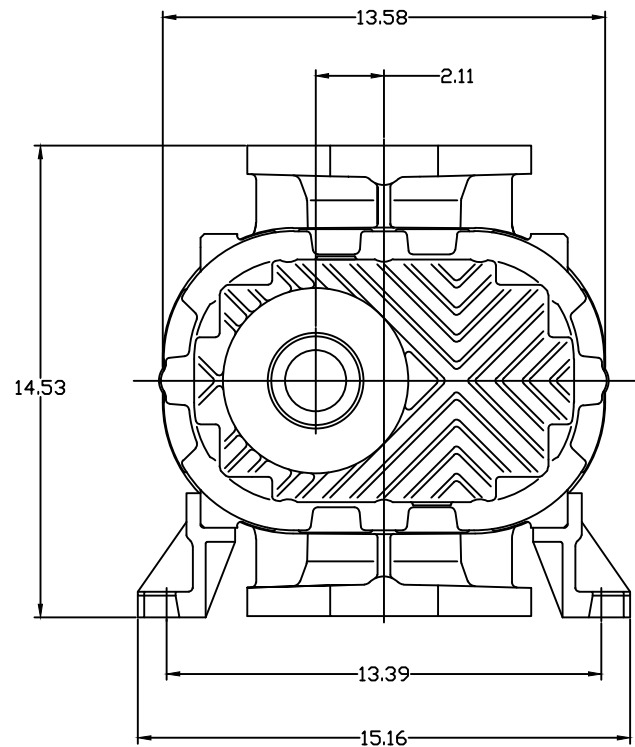

TOTAL WEIGHT 317 lbs

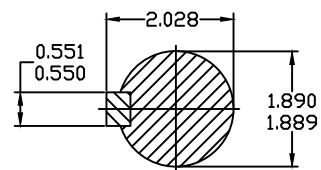

PART. T

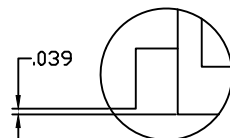

FINISH OF CHAMFERS & FILLETS TO CONFORM TO ROUGHEST ADJACENT AREA.
 SURFACE ROUGHNESS MAX. PER ASME B46.1 SPEC. FULL THD DEPTHS ARE MINIMUM.

CONFIDENTIAL - THE INFORMATION CONTAINED IN THIS DOCUMENT IS THE PROPERTY OF GARDNER DENVER, INC. IT IS NOT FOR PUBLIC DISCLOSURE. POSSESSION OF THE INFORMATION DOES NOT CONVEY ANY RIGHT TO LOAN, SELL OR DISCLOSE THE INFORMATION. UNAUTHORIZED REPRODUCTION OR USE OF THE INFORMATION IS PROHIBITED. THIS DOCUMENT IS TO BE RETURNED TO GARDNER DENVER, INC. UPON THE COMPLETION OF THE PURPOSE FOR WHICH IT IS LOANED OR UPON REQUEST.

UNLESS OTHERWISE SPECIFIED DIMENSIONS ARE IN INCHES
 TOL. ON DECIMALS: .X = ±.05
 TOL. ON DECIMALS: .XX = ±.02
 TOL. ON DECIMALS: .XXX AS SPECIFIED
 TOL. ON ANGLES: ± 0°-30'

DIMENSIONING AND TOLERANCING PER ASME Y14.5-2009
 THREADS PER ASME B1.1 GAGING SYSTEM 21 U.O.S., ANSI B1.20.1 & B1.20.3



HEAT TREATMENT
 ENG. REF: 273175-0000

Gardner Denver Inc.
 Quincy, IL.

TITLE OUTLINE-BARE UNIT
 RBS 55 HORIZONTAL

FIRST ANGLE PROJECTION

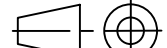

DWN BY L&T 07/11/14
 CK'D BY MWS 07/11/14

SIZE C
 ENGR. APPROVAL -
 DWG NO. 311RBS800
 REV A

SCALE 1:1 SHEET 1 OF 1

4

3

2

1