

REVISIONS						
ZONE	REV	DESCRIPTION	ECN#	DATE	DRAWN	CK'D
--	00	RELEASED	1098970	03MAR2016	L&T	MWS

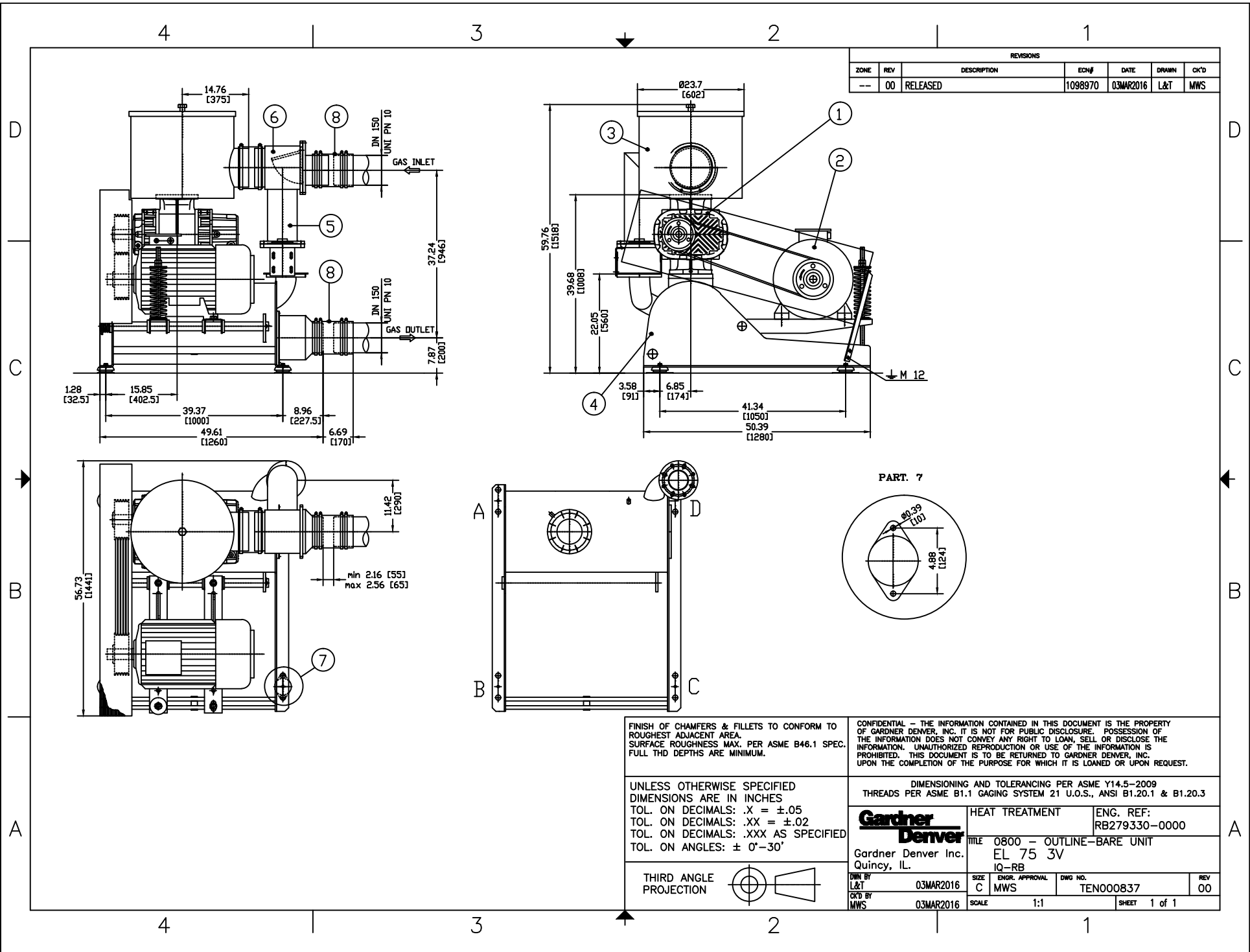

FINISH OF CHAMFERS & FILLETS TO CONFORM TO ROUGHEST ADJACENT AREA. SURFACE ROUGHNESS MAX. PER ASME B46.1 SPEC. FULL THD DEPTHS ARE MINIMUM.

CONFIDENTIAL - THE INFORMATION CONTAINED IN THIS DOCUMENT IS THE PROPERTY OF GARDNER DENVER, INC. IT IS NOT FOR PUBLIC DISCLOSURE. POSSESSION OF THE INFORMATION DOES NOT CONVEY ANY RIGHT TO LOAN, SELL OR DISCLOSE THE INFORMATION. UNAUTHORIZED REPRODUCTION OR USE OF THE INFORMATION IS PROHIBITED. THIS DOCUMENT IS TO BE RETURNED TO GARDNER DENVER, INC. UPON THE COMPLETION OF THE PURPOSE FOR WHICH IT IS LOANED OR UPON REQUEST.

UNLESS OTHERWISE SPECIFIED DIMENSIONS ARE IN INCHES  
 TOL. ON DECIMALS: .X = ±.05  
 TOL. ON DECIMALS: .XX = ±.02  
 TOL. ON DECIMALS: .XXX AS SPECIFIED  
 TOL. ON ANGLES: ± 0°-30'

DIMENSIONING AND TOLERANCING PER ASME Y14.5-2009  
 THREADS PER ASME B1.1 GAGING SYSTEM 21 U.O.S., ANSI B1.20.1 & B1.20.3

**Gardner Denver** HEAT TREATMENT ENG. REF: RB279330-0000

Gardner Denver Inc. Quincy, IL. TITLE 0800 - OUTLINE-BARE UNIT EL 75 3V IQ-RB

THIRD ANGLE PROJECTION

DWN BY L&T	03MAR2016	SIZE C	ENGR. APPROVAL MWS	DWG NO. TEN000837	REV 00
CK'D BY MWS	03MAR2016	SCALE 1:1	SHEET 1 of 1		