



Multistage Centrifugal Blower 675 Series

Hoffman and Lamson present state-of-the-art technology in Multistage Centrifugal Blowers. This model offers a wide range of design features and incorporates energy efficiency improvements, complying with the strictest operational requirements of a variety of applications. Multistage blowers are ideally suited for operations where a variable flow at constant pressure is required. Hoffman and Lamson are worldwide leaders in Multistage Centrifugal Blower technology with thousands of units installed around the globe.

Technical Data

- Number of stages: 1 through 5 (6 at 50 Hz)
- Inlet connection: 24" (610 mm), Flange ANSI 125# drilling
- Outlet connection: 20" (508 mm), Flange ANSI 125# drilling
- Operating speed: 3570 RPM
- Seals: Labyrinth (air) & Carbon rings (special gas)
- Bearings: Long life, balls, single row, AFBMA B-10 std
- Lubrication: Oil
- Max casing pressure: 25 PSIG (1.7 bar)
- Impeller diameter: 35" (889 mm)
- Impeller tip speed: 545 FPS (166 m/s) at 3570 RPM
- Drive: Direct or gear increaser
- Shaft end: 3 3/8" (85.7 mm) / square key 7/8" (22.23 mm)
- Rotor balance: Each impeller & complete rotating assemblies are dynamically balanced as per ISO G2.5
- Casing drainage: 1/2" NPT (heads & sections)
- Cooling: Fan (if needed)
- Balance piston: Standard
- Jacking bolts: Standard for motor and blower alignment
- Machine mounting pads: Standard for blower and motor
- Impeller eye seal: Axial labyrinth type for improved efficiency

Performance Air Map

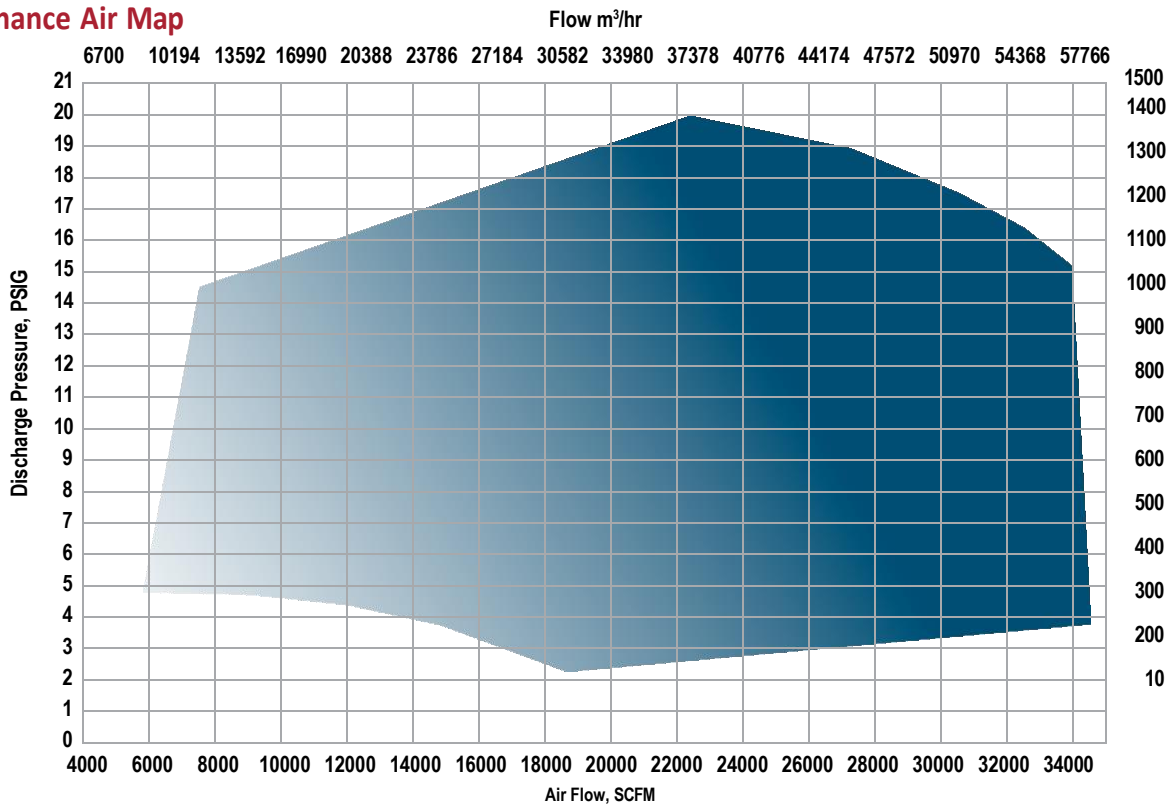

STANDARD CONDITIONS: 14.7 PSIA [1 Bar], 68°F [20°C], 36% RH, Speed: 3550 RPM

General Arrangement

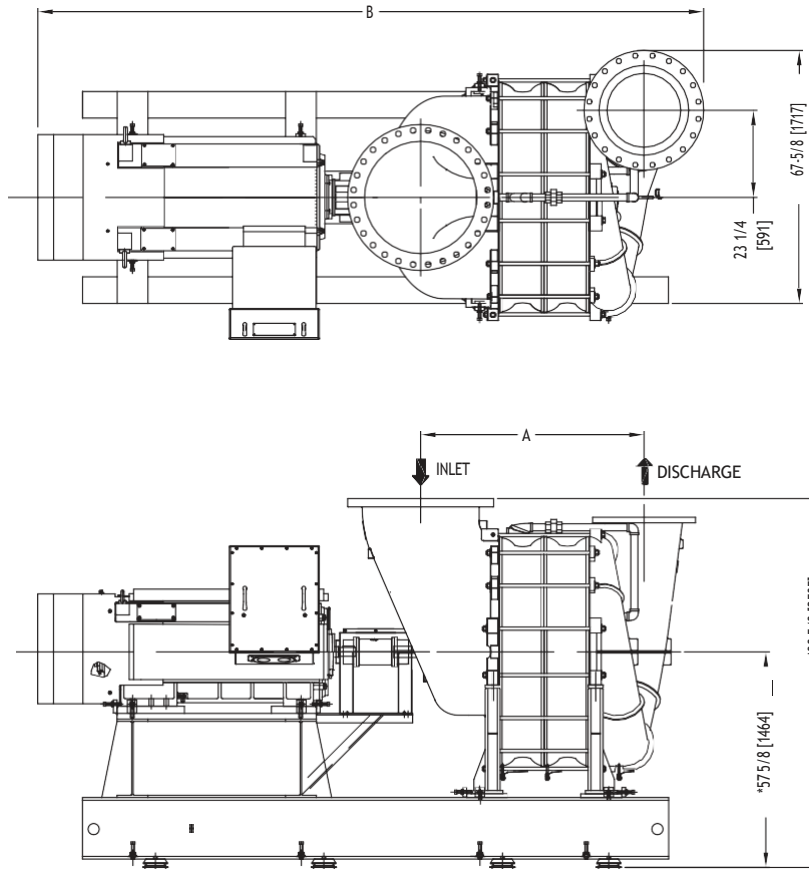

Material Standard

- Casing ASTM A48 Class 30B Gray Cast Iron - HT200 equivalent
- Bearing housing: Cast Iron ASTM A48 class 30B
- Tie rods: High strength carbon steel ASTM A193-B7
- Section seals (O-rings): Fluorocarbon
- Shaft: Carbon steel AISI 4140 (Std) or Stainless (Option)
- Impellers: Cast Aluminum
- Baffle rings: Stainless steel 304
- Base: Structural carbon steel

Dimensional Data - inches [millimeters] Weight – lb [kg] & Inertia– lb-ft² [kg-m²]

MODEL	A	B	ROTOR WK ² lb. ft ² (kg. m ²)	WEIGHT (Blower only)	
	INCH (mm)	INCH (mm)		lb	kg
675.02	42.75 (1086)	Consult factory	246 (10.04)	9449	4295
675.03	53.00 (1346)		354 (15.0)	11823	5374
675.04	63.25 (1607)		462 (19.6)	14197	6453
675.05	73.50 (1867)		570 (24.2)	16571	7532
675.06	83.75 (2127)		678 (28.7)	18945	8611

Product Notes

1. Information is approximate, subject to change without notice, and not for construction use unless certified
 2. Position shown is standard inlet & outlet orientation
 3. Performances noted are typical and not job specific
 4. Consult authorized sales representative for job specific blower or exhauster performance sizing
 5. Factory ASME PTC-10 test offered for performance verification
- * The package height might change slightly due to the vibration isolator selection.



200 Simko Blvd.
Charleroi, PA 15022
USA

HOFFMANandLAMSON.com

©2022 Gardner Denver Nash